

Ordering code

6101.80.stroke. B . _

Side supply ports closed
L = Top supply ports closed

Construction characteristics

Body	anodised aluminium
Rods	C43 chromed steel
Piston	aluminium
Piston rod	C43 chromed steel
Piston rod bushing	sintered bronze
Rod bushing	teflon coated bush
End cover / End plate	aluminium
Piston seal	NBR oil-resistant rubber
Piston rod seal	PUR
Plate	anodised aluminium

Technical characteristics

Function	double acting
Fluid	filtered and preferably lubricated air or not (If lubricated the lubrication must be continuous)
Max. pressure	max. 10 bar
Working temperature	-5°C - +70°C
Cushioning	elastic bumper on both ends

Standard strokes

Bore	Stroke							
	25	50	75	100	125	150	175	200
Ø80	●	●	●	●	●	●	●	●

Intermediate strokes can be obtained by adding specific spacers (5, 10, 15, 20mm)

Example: It is possible to obtain a **6101.80.45.B** cylinder from a **6101.80.50.B** cylinder by adding a 5mm spacer (the overall dimension will remain as per the 50mm stroke). The Intermediate strokes manufactured without the use of spacers are considered special executions.

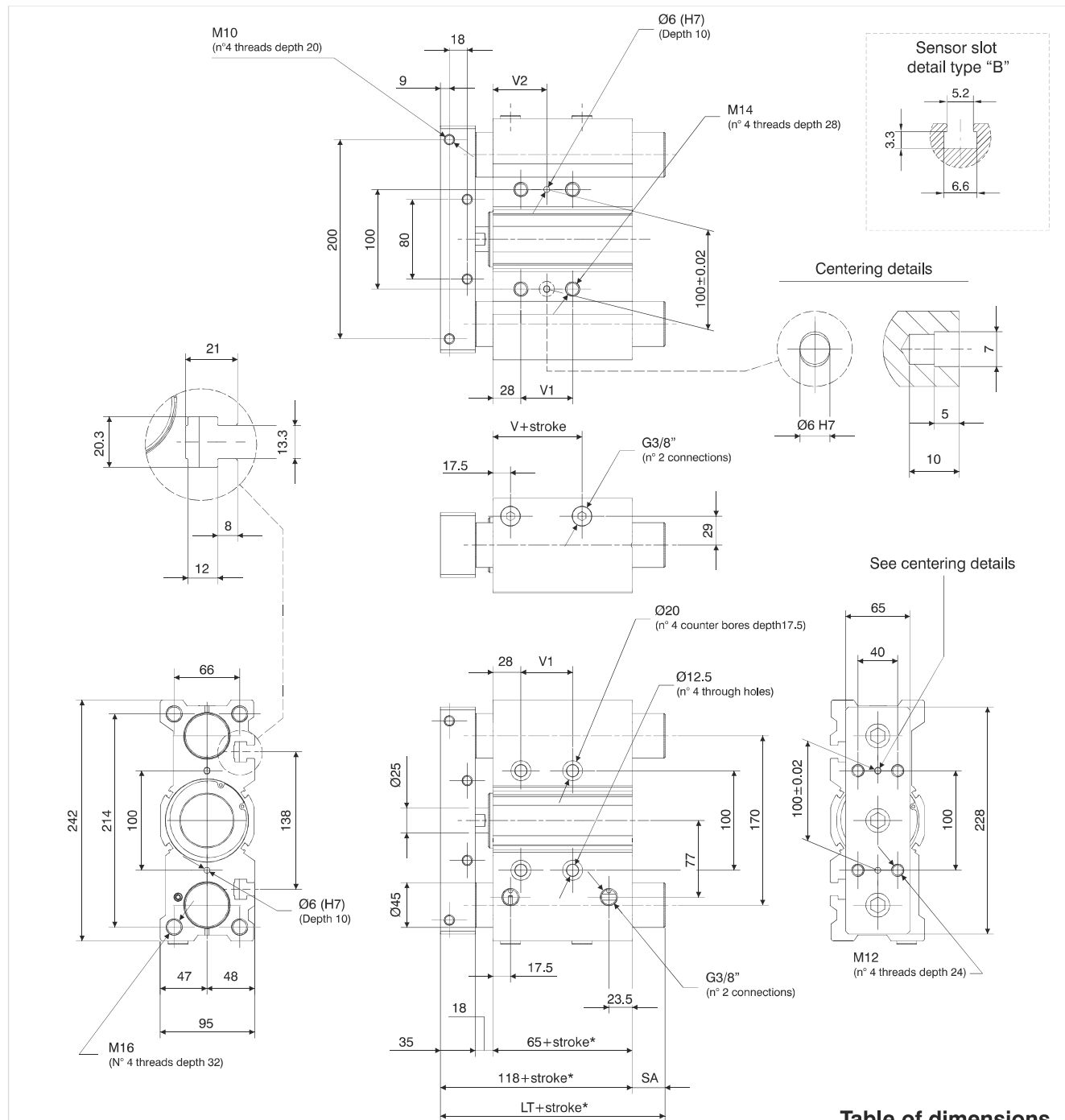

*Dimensions only refer to the "standard stroke"

Table of dimensions

stroke	25	LT	118
	50		118
	> 50		151
		V	14.5
stroke	25	V1	28
	50		52
	75		52
	100		52
	>100		128
stroke	25	V2	42
	50		54
	75		54
	100		54
	>100		92
stroke	25	SA	0
	50		
	> 50		33

Cylinder theoretic force (N)

Working pressure		
2 bar	1005	907
3 bar	1508	1361
4 bar	2011	1814
5 bar	2513	2268
6 bar	3016	2721
7 bar	3519	3175
8 bar	4021	3629
9 bar	4524	4082
10 bar	5027	4536
Effective area (mm ²)	uscita	rientro
	5027	4536

Recommended torque moments

Stroke	N/m
25	49
50	41
75	51
100	45
125	41
150	38
175	35
200	32

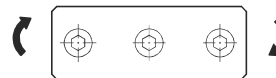

“Stopper” device applications

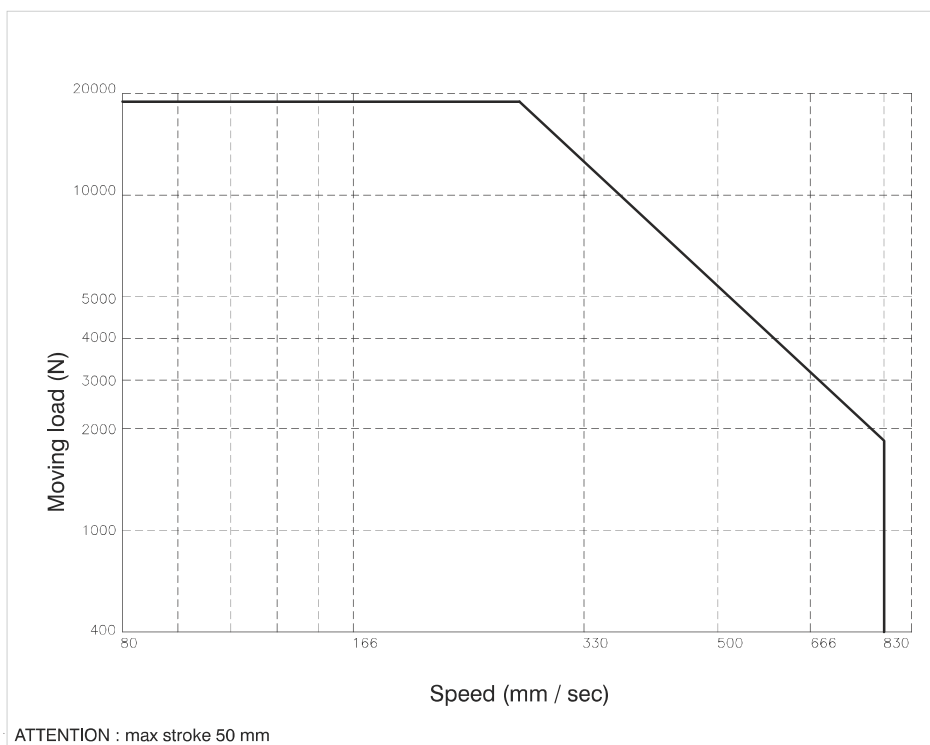
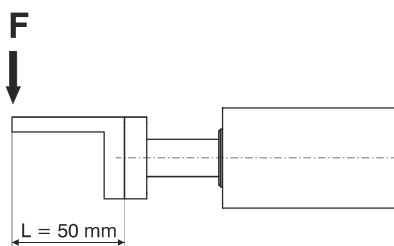
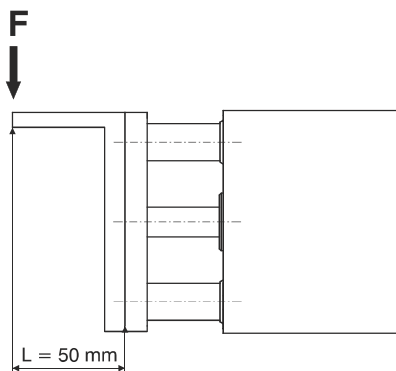



Handling applications

VERTICAL assembly position

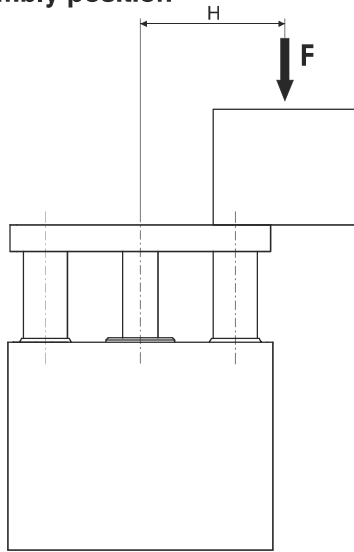

HORIZONTAL assembly position

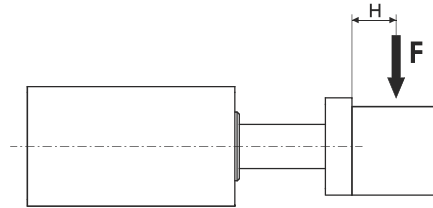

STROKE ≤ 50 mm / V = 200 mm/s

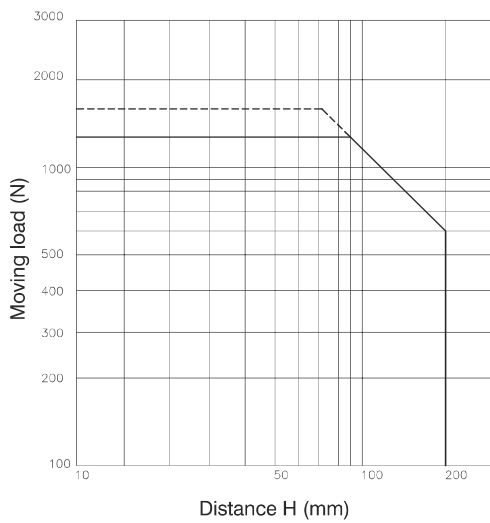

H = 50 mm / V = 200 mm/s

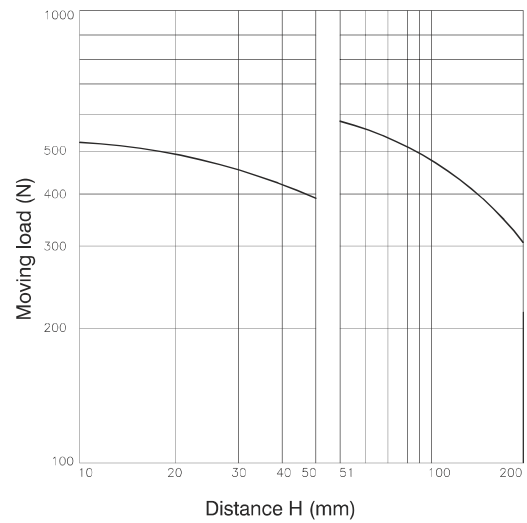

STROKE > 50 mm / V = 200 mm/s

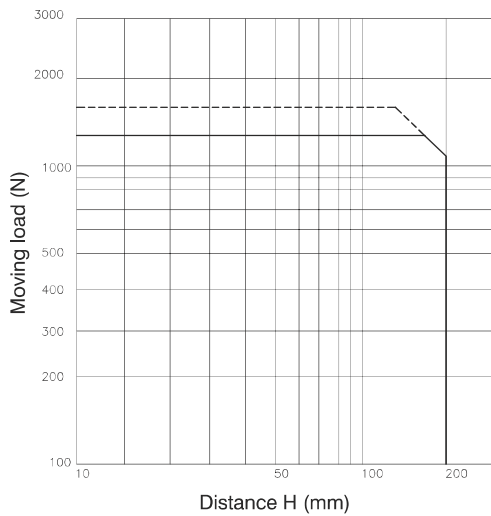

H = 100 mm / V = 200 mm/s

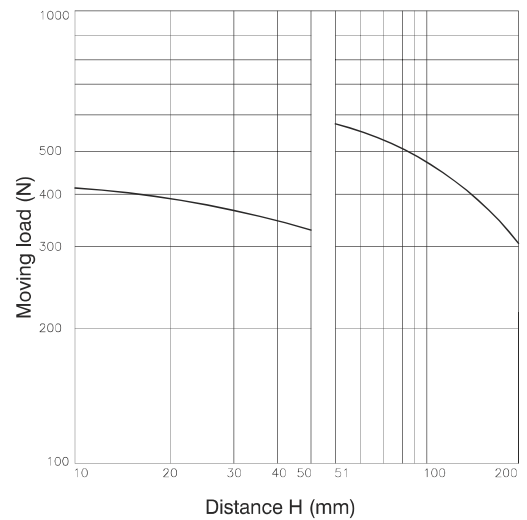

———— Working pressure : 4 bar
- - - - - Working pressure : 5 bar